

SCA620 Series

Accelerometer

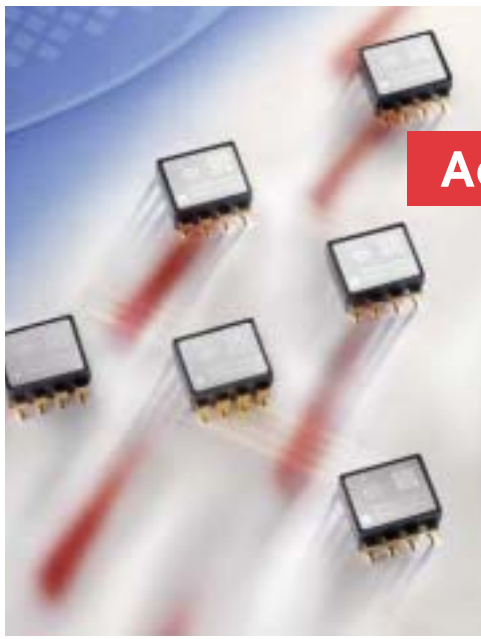

FEATURES

- Available ranges $\pm 1.5g$, $\pm 1.7g$
- 8-pin plastic surface mount DIP package mountable with pick and place machines
- Enhanced failure detection
- Digitally activated electrostatic self test
- Calibration memory parity check
- Continuous connection failure detection
- Bi-directional acceleration measurement
- Controlled frequency response in the sensing element
- Re-flow solderable, process compatible
- Single +5V supply; ratiometric voltage output in the range 4.75 ... 5.25V

BENEFITS

- Exceptional reliability, unprecedented accuracy and excellent stability over temperature and time
- Outstanding overload and shock durability
- No additional components required

APPLICATIONS

- Acceleration measurement
- Inclination measurement
- Motion measurement
- Vibration measurement

For customised product please contact VTI Technologies

ELECTRICAL CHARACTERISTICS

| Parameter | Condition | Min. | Typ. | Max. | Units |
|-----------------------------|--------------------|------|------|------|-------|
| Supply voltage Vdd | | 4.75 | | 5.25 | V |
| Current consumption | Vdd = 5V; No load | | 2.0 | 4.0 | mA |
| Operating temperature | | -40 | | +125 | °C |
| Resistive output load | Vout to Vdd or Vss | 20 | | | kOhm |
| Capacitive load | Vout to Vdd or Vss | | | 20 | nF |
| Output noise ⁽¹⁾ | DC...80kHz | | 0.25 | | mg |

VDD = 5.00V, UNLESS OTHERWISE SPECIFIED

PERFORMANCE CHARACTERISTICS

| Parameter | Condition/Comment | SCA620-CF8H1A | Units |
|--|----------------------------|-------------------------|-------|
| Measuring range ⁽²⁾ | Nominal | ± 1.7 | g |
| Measuring direction ⁽³⁾ | Mountin plane vert. | Horizontal | |
| Zero point (nom.) ⁽⁴⁾ | Mounting position | Vdd/2 | V |
| Sensitivity | @ room temperature | 1.2 ⁽⁵⁾ | V/g |
| Zero point error ⁽⁶⁾ | -40...125°C | ± 125 | mg |
| Zero point tempco ⁽⁷⁾ | -25...85°C | 0.3 \pm 0.6 | mg/°C |
| Sensitivity error | -40...125°C | ± 4 ⁽⁸⁾ | % |
| Sensitivity error ⁽⁷⁾ | -25...85°C | ± 3 ⁽⁸⁾ | % |
| Typical non-linearity ⁽⁷⁾ | Over measuring range | ± 40 ⁽⁹⁾ | mg |
| Cross-axis sensitivity ⁽¹⁰⁾ | | 5 | % |
| Frequency response | -3dB point ⁽¹¹⁾ | 50 \pm 30 | Hz |
| Ratiometric error ⁽¹²⁾ | Vdd = 4.75...5.25V | 2 | % |

Note 1 The noise density of CF8H1A is 20 μ g/ \sqrt Hz.

Note 2 The measuring range is limited by sensitivity, offset and supply voltage rails of the device.

Note 3 Measuring direction perpendicular to the mounting plane.

Note 4 Vertical versions in +1g position pins down, horizontal versions leg row 1-4 pointing downwards.

Note 5a Sensitivity specified as $[V_{out}(+1g) - V_{out}(-1g)] / 2 [V/g]$.

Note 6 Zero point error specified as $(V_{out}(+0g) - V_{dd}/2) / V_{sens}$ [g] (room temp. error included); Vsens = Nominal sensitivity.

Note 7 Typical tolerance, not 100 % tested.

Note 8 Sensitivity error specified as $\{([V_{out}(+1g) - V_{out}(-1g)] / 2) - V_{sens}\} / V_{sens} \times 100\%$ [%] (room temp. error included); Vsens = Nominal sensitivity.

Note 9 Relative to straight line between $\pm 1g$.

Note 10 The cross-axis sensitivity determines how much acceleration, perpendicular to the measuring axis, couples to the output. The total cross-axis sensitivity is the geometric sum of the sensitivities of the two axes, which are perpendicular to the measuring axis.

Note 11 The output has true DC (0Hz) response.

Note 12 Supply voltage noise also couples to the output, due to the ratiometric (output proportional to supply voltage) nature of the accelerometer.

The ratiometric error is specified as: $RE = 100\% \times \left[1 - \frac{V_{out}(@V_x) \times \frac{5.00V}{V_x}}{V_{out}(@5V)} \right]$

ABSOLUTE MAXIMUM RATINGS

| Parameter | Value | Units |
|---------------------------------------|-------------------|-------|
| Acceleration (powered or non-powered) | 20000 | g |
| Supply voltage | -0.3 to +7.0 | V |
| Voltage at input / output pins | -0.3 to Vdd + 0.3 | V |
| Temperature range | -55 to + 125 | °C |

ELECTRICAL CONNECTION

| Pin# | Pin Name | Connection |
|------|----------|---|
| 1 | | Open or capacitively connected to GND for EMC |
| 2 | | Open or capacitively connected to GND for EMC |
| 3 | | Open or capacitively connected to GND for EMC |
| 4 | | Negative supply voltage (VSS) |
| 5 | | Open or capacitively connected to GND for EMC |
| 6 | ST | Self-test control |
| 7 | VOUT | Sensor analog output |
| 8 | VDD | Positive supply voltage (VDD) |

RECOMMENDED CIRCUIT

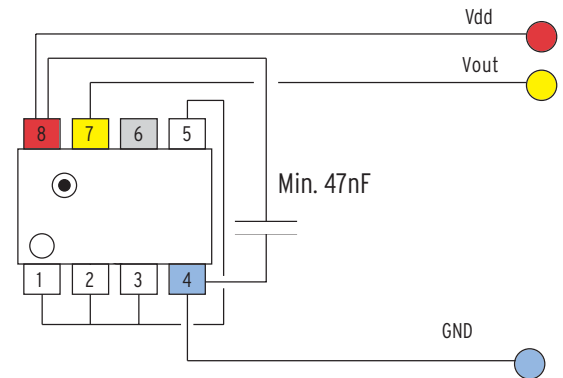

DIMENSIONS

PCB PAD LAYOUTS

The accelerometer weighs under 1g. The size of the part is approximately (w x h x l) 9 x 5 x 11 mm. Pin pitch is standard 100 mils.

