

SCA100T Series

Inclinometer

FEATURES

- 2-axis inclination measurement (X and Y)
- Available ranges $\pm 0.5g$ ($\pm 30^\circ$), $\pm 1.0g$ ($\pm 90^\circ$)
- Sensing element controlled frequency response
- DIL-12 plastic SMD package, lead free reflow solderable
- Advanced internal and external connection failure detection
- Digitally activated electrostatic sensing element self test
- Continuous memory parity check
- Single +5V supply; ratiometric voltage output
- Serial Peripheral Interface (SPI) compatible
- Field calibration possibility
- Internal temperature sensor, accessible via SPI

BENEFITS

- Excellent reliability and stability over time and temperature
- Instrumentation grade performance
- High resolution and low noise
- Wide temperature range
- Outstanding overload and shock durability

APPLICATIONS

- 2-axis platform levelling
- Inclination based position measurement
- Tilt measurement with cross-axis compensation
- 360° vertical orientation measurement

ELECTRICAL CHARACTERISTICS

Parameter	Condition	Min	Typ.	Max	Units
Supply voltage Vdd ⁽¹⁾		4.75	5.0	5.25	V
Current consumption	Vdd = 5 V; No load		4	6	mA
Analogue output load	Vout to Vdd or Vss	10			kOhm
				20	nF
Digital output load	@ 500kHz			1	nF
SPI clock frequency				500	kHz
AD conversion time			150		ms
Data transfer time	@500 kHz clock		38		ms

PERFORMANCE CHARACTERISTICS

Parameter	Condition	SCA100T-D01 ($\pm 30^\circ$)	SCA100T-D02 ($\pm 90^\circ$)	Units
Measuring range ⁽²⁾	Nominal	$\pm 30^\circ$ ⁽²⁾	± 90	$^\circ$
		± 0.5	± 1	g
Measuring direction ⁽³⁾	Mounting plane horizontal	Dual axis inclination	Dual axis inclination	
	Mounting plane vertical	Orthogonal rotation	Orthogonal rotation	
Zero point ⁽⁴⁾	Mounting position	Vdd/2	Vdd/2	V
Sensitivity	@ room temperature	4 ^(5a)	2 ^(5b)	V/g
Offset calibration accuracy ^(6a,13)	@ room temperature	± 2	± 4	mg
Offset temperature dependency ^(6b)	0...70°	± 5	± 5	mg
	-25...85°C	± 10	± 10	mg
	-40...125°C	± 15	± 15	mg
Sensitivity calibration accuracy ^(7a,13)	@ room temperature	0.5	0.5	%
Sensitivity temperature error ^(7b)	-40...85°C	-1..1	-1..1	%
	85...125°C	-2.5..1	-2.5..1	%
Typical non-linearity ⁽⁸⁾	Over measuring range	± 2	± 10	mg
Cross-axis sensitivity ⁽¹¹⁾	@ room temperature	4	4	%
Alignment error between sensing axes		T.B.D	T.B.D	$^\circ$
Frequency response -3dB (LP) ⁽⁹⁾	@ room temperature	8...28	8...28	Hz
Ratiometric error ⁽¹⁰⁾	Vdd = 4.75...5.25V	± 2	± 2	%
Output noise density ⁽¹²⁾	From DC...100Hz	15	15	$\mu\text{g}/\sqrt{\text{Hz}}$
Digital output resolution	FS	11	11	Bits
Long term stability ⁽¹⁴⁾	@ steady temp	0.25	T.B.D	mg

VDD = 5.00 V, APPLIES TO BOTH CHANNELS UNLESS OTHERWISE SPECIFIED

Note 1. For maximum accuracy the supply voltage should be 5 ± 0.05 V. 100nF supply filtering capacitor is recommended

Note 2. The measuring range is limited by sensitivity, offset and supply voltage rails of the device.

Note 3. Measuring directions in parallel to mounting plane, arrows showing positive acceleration direction

Note 4. Offset specified as Voffset = Vout(0g) [V]. See note 12.

Note 5a. Sensitivity specified as Vsens = (Vout(+0.5g) - Vout(-0.5g))/1 [V/g]. See note 12

Note 5b. Sensitivity specified as Vsens = (Vout(+1g) - Vout(-1g))/2 [V/g]. See note 12

Note 6a. Offset calibration error specified as Offset_Calib_error = (Vout(0g) - Vdd/2) / Vsens [g]

Note 6b. Offset temperature error specified as Offset Error @ temp. = (Vout @ temp. - Vout @ room temp.) / Vsens [g]

Note 7a. Sensitivity calibration error specified as Sensitivity_calibr_error = { (Vout(+0.5g)-Vout(-0.5g)) / (1 - Vsens_nom) } / Vsens_nom x 100% [%] Vsens_nom = nominal sensitivity

Note 7b. Sensitivity temperature error specified as Sensitivity error @ temp = { [Vsens @ temp - Vsens @ room temp] / Vsens @ room temp x 100% [%]

Note 8. From straight line through sensitivity calibration point.

Note 9. The output has true DC (0Hz) response.

Note 10. The ratiometric error is specified as:
$$RE = 100\% \times \left[1 - \frac{V_{out}(@V_x) \times \frac{5.00V}{V_x}}{V_{out}(@5V)} \right]$$

Note 11. The cross-axis sensitivity determines how much inclination / acceleration, perpendicular to the measuring axis, couples to the output. The total crossaxis sensitivity is the geometric sum of the sensitivities of the two axes which are perpendicular to the measuring axis.

Note 12. In addition, supply voltage noise couples to the output due to the ratiometric nature of the accelerometer.

Note 13. Factory calibration value

Note 14. Power continuously connected.

MEASURING DIRECTIONS

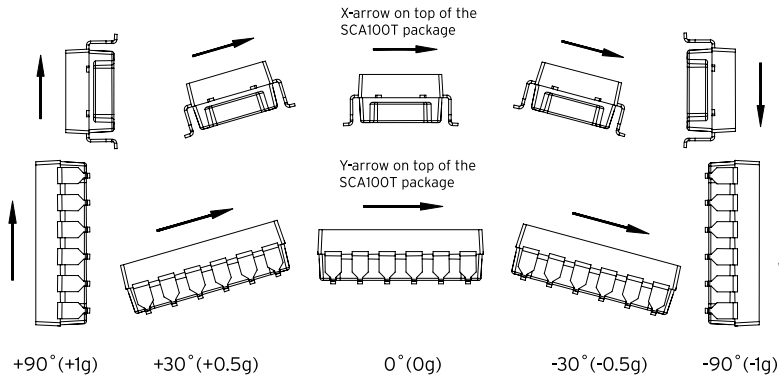

ABSOLUTE MAXIMUM RATINGS

Parameter	Value	Unit
Acceleration (powered or....)	20 000	g
Supply voltage	-0.3 V to +5.5 V	V
Voltage at input/output pins	-0.3 V to (Vdd+0.3V)	V
Temperature range	-55...125	°C

ELECTRICAL CONNECTION

Pin#	Pin Name	I/O	Connection
1	SCK	Input	Serial clock
2		NC	Factory only
3	MISO	Output	Master in slave out; data output
4	MOSI	Input	Master out slave in; data input
5	Out_2	Output	Y axis Output (Ch 2)
6	VSS	Power	Negative supply voltage (VSS)
7	CSB	Input	Chip select (active low)
8		NC	Factory only
9	ST_2	Input	Self test input for Y axis (Ch 2)
10	ST_1 / Test_in	Input	Self test input for X axis (Ch 1)
11	Out_1	Output	X axis output (Ch 1)
12	VDD	Power	Positive supply voltage (VDD)

If the SPI interface is not used SCK (pin1), MISO (pin3), MOSI (pin4) and CSB (pin7) must be left floating.

Self test can be activated applying logic "1" (positive supply voltage level) to ST pin (pin 9 and 10). If ST feature is not used pins 9 and 10 must be left floating or connected to GND.

RECOMMENDED CIRCUIT

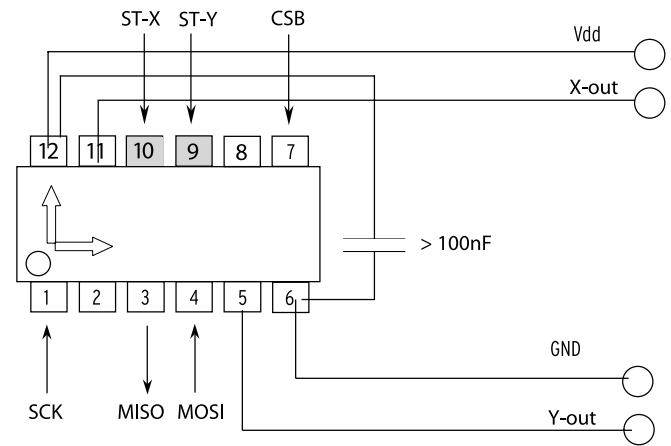

DIMENSIONS

The part weights under 1.2g. The size is appr. (w x h x l) 9 x 5 x 16 mm. Pin pitch is standard 100 mils.

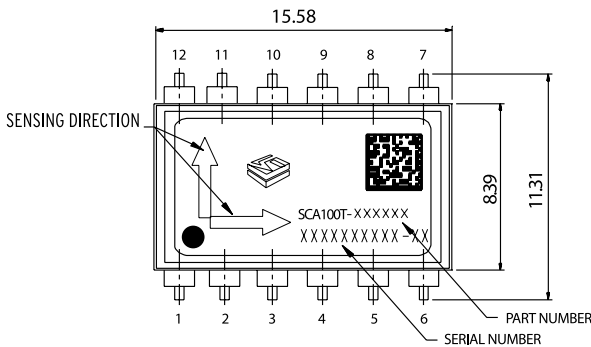

Acceleration in the direction of the arrow will increase the output voltage.

PCB PAD LAYOUTS

