

SCA61T Series

Inclinometer / Accelerometer

FEATURES

- Available ranges $\pm 0.5g$ ($\pm 30^\circ$), $\pm 1.0g$ ($\pm 90^\circ$)
- Sensing element controlled frequency response
- DIL-8 plastic SMD package, lead free reflow solderable
- Advanced internal and external connection failure detection
- Digitally activated electrostatic sensing element self test
- Continuous memory parity check
- Digital and analogue acceleration output
- Serial Peripheral Interface (SPI) compatible
- Field calibration possibility
- Internal temperature sensor, accessible via SPI

BENEFITS

- Excellent reliability and stability over time and temperature
- Instrumentation grade performance
- High resolution and low noise
- Wide temperature range
- Outstanding overload and shock durability

APPLICATIONS

- Inclination instruments
- Position measurement
- Acceleration and motion measurement

For customised product please contact
VTI Technologies

ELECTRICAL CHARACTERISTICS

Parameter	Condition	Min.	Typ.	Max.	Units
Supply voltage Vdd ⁽¹⁾		4.75	5.0	5.25	V
Min output voltage	Limiter enabled	0.25			V
Max output voltage	Limiter enabled			4.75	V
Current consumption	Vdd = 5V; No load		4	6	mA
Analogue output load	Vout to Vdd or Vss	10			kOhm
Digital output load	@ 500kHz			20	nF
SPI clock frequency				1	nF
AD conversion time		150		500	kHz
Data transfer time	@ 500kHz	38			μ s

VDD = 5.00V, UNLESS OTHERWISE SPECIFIED

PERFORMANCE CHARACTERISTICS

Parameter	Condition	SCA61T-FAHH1G	SCA61T-FA1H1G	Units
Measuring range ⁽²⁾	Nominal	± 0.5 ($\pm 30^\circ$)	± 1 ($\pm 90^\circ$)	g
Measuring direction ⁽³⁾	Mounting plane horiz.	Horizontal	Horizontal	
Zero point ⁽⁴⁾	Mounting position	Vdd/2	Vdd/2	V
Sensitivity ⁽⁵⁾	@ room temperature	4 ^(5b)	2 ^(5a)	V/g
Offset calibration accuracy ^(6,13)	@ room temperature	2	4	mg
Offset temperature dependency ⁽⁶⁾	0...70°C	± 5	± 5	mg
	-25...85°C	± 10	± 10	mg
	-40...125°C	± 15	± 15	mg
Sensitivity calibration accuracy ⁽¹³⁾	@ room temperature	0.5	0.5	%
Sensitivity temperature error ^(7,13)	0...70°C	± 1	± 1	%
	-25...85°C	± 1.5	± 1.5	%
	-40...125°C	± 2	± 2	%
Typical non-linearity ⁽⁸⁾	Over measuring range	± 5	± 10	mg
Cross-axis sensitivity ⁽¹¹⁾	@ room temperature	4	4	%
Frequency response -3dB (LP) ⁽⁹⁾	@ room temperature	8...28	8...28	Hz
Ratiometric error ⁽¹⁰⁾	Vdd = 4.75...5.25V	2	2	%
Output noise density ⁽¹²⁾	From DC...100Hz	15	T.B.D.	μ g/ \sqrt Hz
Digital output resolution	FS	11	11	Bits
Short term stability	Temp. var. max. 0...70°C	± 3	T.B.D.	mg
Long term stability ⁽¹⁴⁾	@ steady temperature	0.25	T.B.D.	mg

Note 1. For maximum accuracy the supply voltage should be 5 ± 0.05 V. 100nF supply filtering capacitor is recommended.

Note 2. The output is limited by the internal limiter.

Note 3. Measuring direction parallel to mounting plane, arrow showing positive direction

Note 4. Offset specified as Voffset = Vout(0g) [V]. See note 12.

Note 5a. Sensitivity specified as Vsens = (Vout(+1g) - Vout(-1g))/2 [V/g]. See note 12

Note 5b. Sensitivity specified as Vsens = (Vout(+0.5g) - Vout(-0.5g))/1 [V/g]. See note 12

Note 6. Offset error specified as Offset Error = (Vout(0g)-Vdd/2) / Vsens [g]

Vsens = Nominal sensitivity

Vdd/2= Nominal offset

See note 12.

Note 7. Sensitivity error specified as Sensitivity Error = { [Vout(+0.5g)-Vout(-1g)] / 2-Vsens} / Vsens x 100% [%]

Vsens = Nominal sensitivity

See note 12.

Note 8. From straight line through sensitivity calibration points.

Note 9. The output has true DC (0Hz) response

Note 10. The ratiometric error is specified as. $RE = 100\% \times \left[1 - \frac{Vout(@Vx) \times \frac{5.00V}{Vx}}{Vout(@5V)} \right]$

Note 11. The cross-axis sensitivity determines how much inclination / acceleration, perpendicular to the measuring axis, couples to the output. The total cross-axis sensitivity is the geometric sum of the sensitivities of the two axis which are perpendicular to the measuring axis.

Note 12. In addition, supply voltage noise couples to the output due to the ratiometric nature of the accelerometer.

Note 13. Factory calibration value.

Note 14. Power continuously connected.

ABSOLUTE MAXIMUM RATINGS

Parameter	Value	Units
Acceleration (powered or non-powered)	20000	g
Supply voltage	-0.3 V to +5.5 V	V
Voltage at input / output pins	-0.3 to (Vdd + 0.3)	V
Temperature range	-55 to +125	°C

ELECTRICAL CONNECTION

Pin#	Pin Name	I/O	Connection
1	SCK	Input	Serial clock
2	MISO	Output	Master in slave out; data output
3	MOSI	Input	Master out slave in; data input
4	GND	Power	Negative supply voltage (VSS)
5	CSB	Input	Chip select (active low)
6	ST	Input	Self test input
7	Out	Output	Sensor analog output
8	VDD	Power	Positive supply voltage (VDD)

If the SPI interface is not used SCK (pin1), MISO (pin2), MOSI (pin3) and CSB (pin5) must be left floating.

Self test can be activated applying logic "1" (positive supply voltage level) to ST pin (pin 6). If ST feature is not used pin 6 must be left floating or connected to GND.

RECOMMENDED CIRCUIT

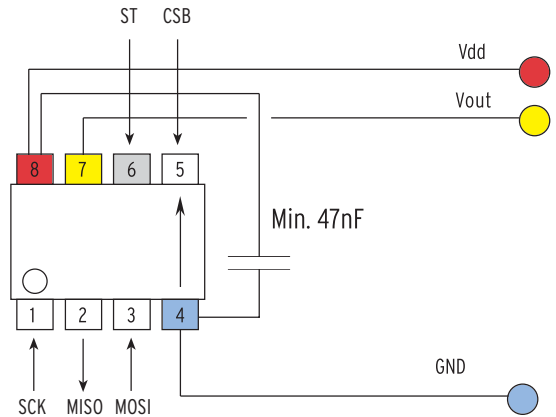

DIMENSIONS

PCB PAD LAYOUTS

The accelerometer weighs under 1g. The size of the part is approximately (w x h x l) 9 x 5 x 11 mm. Pin pitch is standard 100 mils.

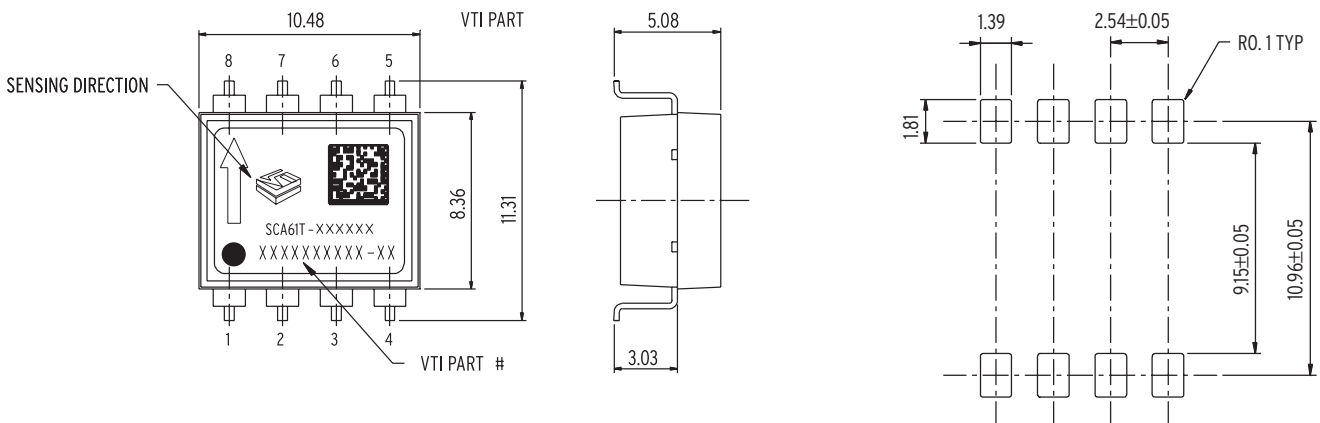

Acceleration in the direction of the arrow will increase the output voltage.